

### THREADED COUPLING

For on-site assembly Patent/DBGM pending

1.4305  
AISI 303

no.	mm	mm	mm	mm	mm	mm	mm	mm
30842-	ø mm	a	b1	b2	b3	ø d	sw	
0200	2,0	M6	80	44	13	14,8	13	
0300	3,0	M6	80	44	13	14,8	13	
0400	4,0	M6	80	44	13	14,8	13	
0500	5,0	M6	82	48	13	17,1	15	
0600	6,0	M6	82	48	13	17,1	15	

### LOOSE SLEEVE

1.4404  
AISI 316

no.	mm	mm	mm	no.	mm	mm	mm
30864-	ø mm	ø d	b	30864-	ø mm	ø d	b
0205	2,0	5	30	0610	6,0	10	30
0206	2,0	6	30	0613	6,0	13	30
0306	3,0	6	30	0813	8,0	13	30
0307	3,0	7	30	1018	10,0	18	50
0310	3,0	10	30	1020	10,0	20	50
0407	4,0	7	30	1222	12,0	22	50
0408	4,0	8	30	1225	12,0	25	50
0410	4,0	10	30	1424	14,0	24	50
0508	5,0	8	30	1627	16,0	27	50
0513	5,0	13	30	1632	16,0	32	50

### DECO SLEEVE FOR UNIVISS®

1.4305  
AISI 303

no. R	no. L	mm	mm	mm	mm	mm
30848-	30849-	ø mm	a	b	ø d	c
0300-01	0300-01	3,0	M3	9	3,9	3,0
0400-01	0400-01	4,0	M4	11	5,0	4,0
0500-01	0500-01	5,0	M5	13	6,5	4,5
0600-01	0600-01	6,0	M6	15	7,5	5,0
0800-01	0800-01	8,0	M8	20	10,0	7,0

### CLEVIS WITH EXTERNAL THREAD

1.4404  
AISI 316

no.	mm	mm	mm	mm	mm	mm	mm	mm	mm	mm
30887-	a	b	c	ø d1	ø d2	e	f1	f2	g	h
0800	M8	72	50	13	5	6	9	16	5	11

### HEADLESS SHAFT SCREW, RIGHT-HAND THREAD

1.4404  
AISI 316

no.	mm	mm	mm	mm	
30882-	a	b1	b2	c1	c2
0801-020	M8	56,5	20	27	9,5
0801-029	M8	65,5	29	27	9,5
0801-039	M8	75,5	39	27	9,5
0801-059	M8	95,5	59	27	9,5

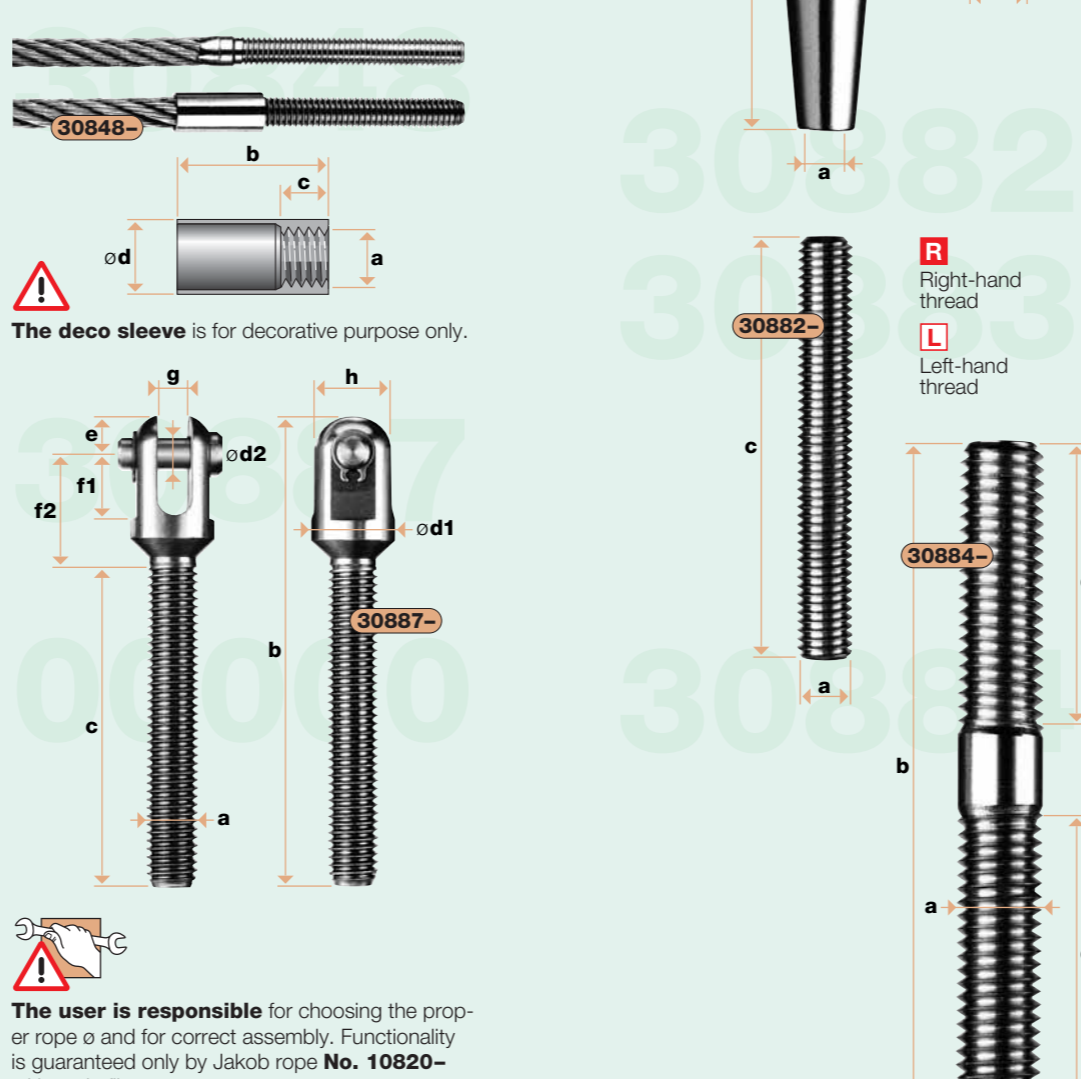
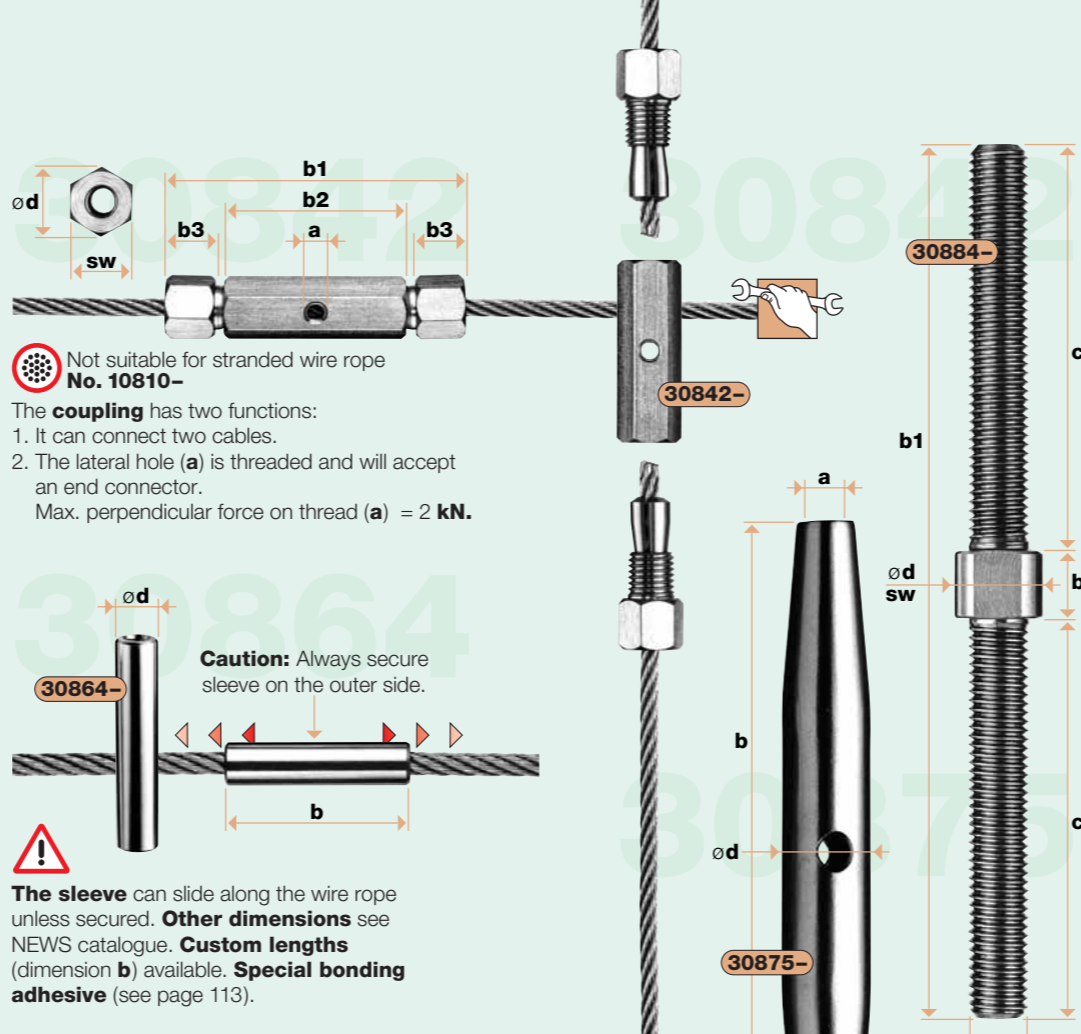
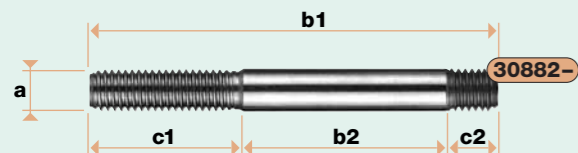

### TENSIONING SCREW WITH RH/LH EXTERNAL THREADS

1.4305  
AISI 303

no.	mm	mm	mm	mm	mm	mm
30884-	a	b1	b2	ø d	c	sw
0400-043	M4	43	5	5	19	4
0500-053	M5	53	5	6	24	5
0500-083	M5	83	5	6	39	5
0600-055	M6	55	5	8	25	6
0600-085	M6	85	5	8	40	6
0800-072	M8	72	8	10	32	8
0800-122	M8	122	8	10	57	8
1000-146	M10	146	10	12	68	10
1200-192	M12	192	12	16	90	13
1400-195	M14	195	15	20	90	17
1600-246	M16	246	20	22	113	19
2000-292	M20	292	20	26	136	22

### TURNBUCKLE WITH RH/LH INTERNAL THREADS

1.4401  
AISI 316

no.	mm	mm	mm	no.	mm	mm	
30875-	a	b	ø d	30875-	a	b	ø d
0500	M5	80	8,0	1400	M14	170	21,3
0600	M6	92	10,0	1600	M16	190	26,9
0800	M8	112	13,5	2000	M20	220	33,7
1000	M10	120	17,2	2400	M24	280	45,0
1200	M12	150	21,3				

### HEADLESS SCREW

1.4404  
AISI 316

no. R	no. L	mm	mm	no. R	no. L	mm	mm
30882-	30883-	a	c	30882-	30883-	a	c
0400-030	0400-030	M4	30	0600-130	0600-130	M6	130
0500-040	0500-040	M5	40	0800-050	0800-050	M8	50
0500-050	0500-050	M5	50	0800-060	0800-060	M8	60
0500-060	0500-060	M5	60	0800-080	0800-080	M8	80
0500-080	0500-080	M5	80	0800-090	0800-090	M8	90
0500-100	0500-100	M5	100	0800-120	0800-120	M8	120
0600-040	0600-040	M6	40	1000-060	1000-060	M10	60
0600-050	0600-050	M6	50	1200-080	1200-080	M12	80
0600-060	0600-060	M6	60	1400-080	1400-080	M14	80
0600-080	0600-080	M6	80	1600-080	1600-080	M16	80
0600-100	0600-100	M6	100	2000-100	2000-100	M20	100

### HEADLESS SCREW RH/LH

1.4404  
AISI 316

no.	mm	mm	mm	no.	mm	mm	
30884-	a	b	c	30884-	a	b	c
0400	M4	45	20	1200	M12	105	50
0500	M5	65	30	1400	M14	105	50
0600	M6	65	30	1600	M16	125	60
0800	M8	65	30	2000	M20	125	60
1000	M10	85	40				